

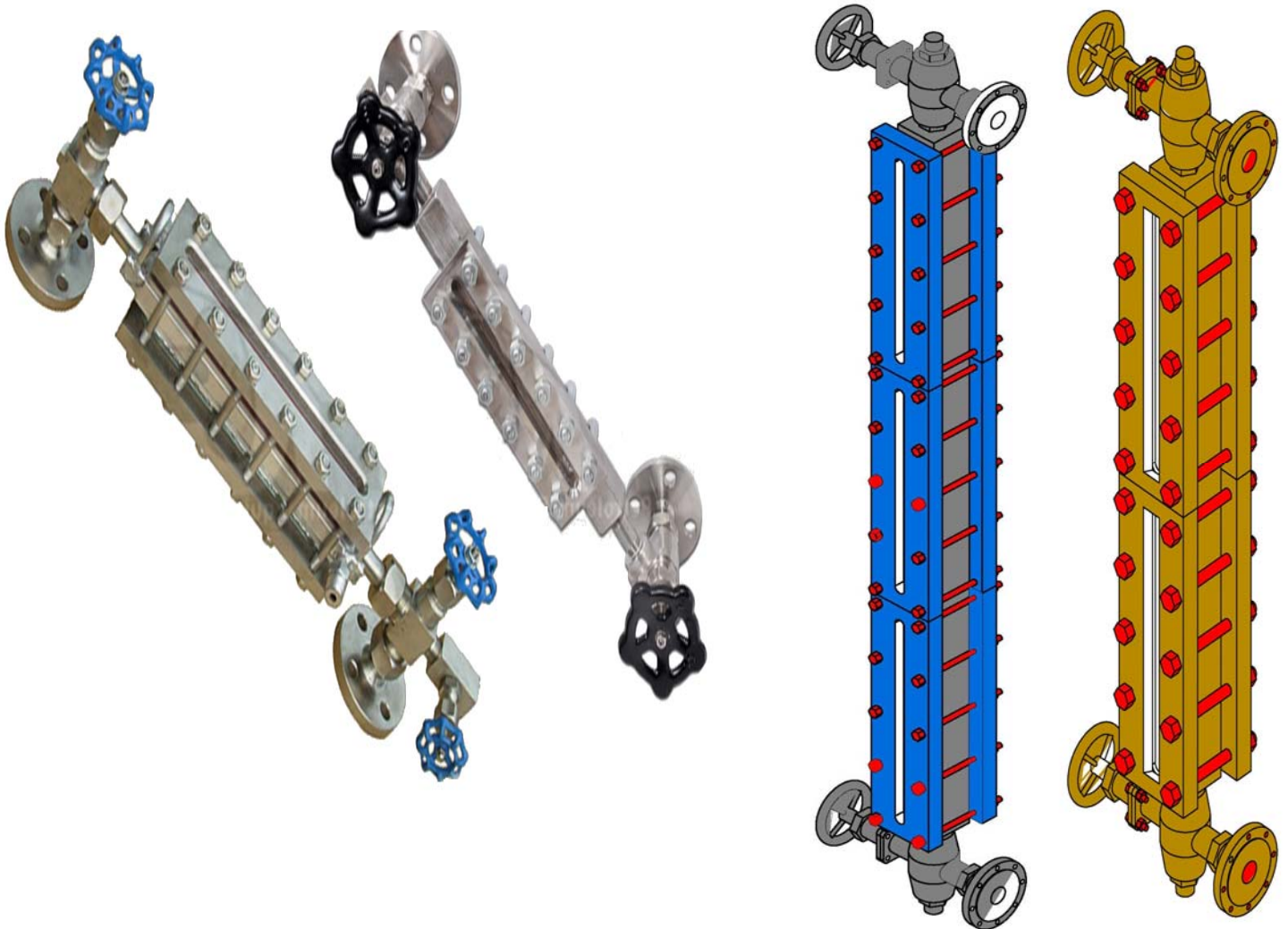

PETROTECH ENGINEERS

TRANSPARENT LIQUID LEVEL GAUGE



CONTACT: PETROTECH ENGINEERS

Web- www.Petrotechengineers.com

Email- info@petrotechengineers.com

LIQUID LEVEL GAUGE

GENERAL DESCRIPTION

Petrotech Liquid level Gauge is a rugged flat glass gauge for Low, medium and high pressure applications and simple, rugged instruments engineered and constructed in work cell to give you accurate liquid level readings for the life of the vessel. To ensure long life, only the best Materials are utilized, from the forged steel valve bodies. In order to control the Quality of each component, all parts are machined on precision CNC equipment. After machining, each Part is carefully inspected before being assembled to the final product in the specialized work cell.

REFLEX/ TRANSPARENT LIQUID LEVEL GAUGE

- ➊ **Reflex Level gauges** are designed to operate based on the difference in the refractive indices of Liquid and vapor. Liquid Flows through the gauge chamber behind the viewing glass located on only one side of the instrument and which is clamped to the gauge body. When liquid is present the glass will appear black where it is in contact with the process medium and when no liquid is present the Glass is silvery / white thus the level can be seen.
- ➋ **Transparent level gauges** are different in design / function to a reflex gauge as they consist of two flat transparent glasses where the light can enter / exit from the back to the front of the Gauge thus illuminating the liquid level which is contained in the chamber separating the two glasses. The liquid level is indicated by the different transparency of the two media.

FEATURES

- **Quality Materials** - Toughened borosilicate glass conforms to BS3463, JIS B8211, Din 7080, and DIN 7081. All parts are ASTM grade and listed in ANSI 31.3.
- **Quality Assurance Testing** - All gauges are hydrostatically tested to 1.5 times the rated pressure at 100°F (38°C).
- **No-Leak Design** - Recessed gasket seat in chamber and cover prevents leaks often caused by shifting gaskets.
- **Liquid-Gas or Liquid-Liquid Interface Applications** - Available in either reflex or transparent styles to satisfy all application requirements
- **NACE Compatible** - Wetted parts conform to NACE MR-01-75 specifications for sour gas service.
- **Marine Option** - 316 SST bolts and nuts plus three-coat paint system, for optimal protection against corrosive environments.

TRANSPARENT LIQUID LEVEL GAUGE

TECHNICAL SPECIFICATION MODEL PETL-30

30 KG/CM² @ 150 °C/ 450 PSI @ 302 °F

DESCRIPTION:

Series **PETL-30** is designed in both single and multiple sections. They are machined from solid bar stock of cold rolled carbon steel, stress relieved and assembled complete with drop forged steel covers, toughened Borosilicate glass, gasket, bolts and nuts making the gauges resistant to thermal shock, heat, corrosion and abrasion. All bolts are properly spaced to ensure uniform pressure on the glass and gaskets and are manufactured from ASTM grade steel. The gaskets used are of the finest quality, uniform in thickness and accurately die cut.

FEATURES:

Liquid Chamber: One piece Carbon steel or stainless steel, Regardless of number of gauges Sections. Standard and optional Materials CS, ASTM A 105, SS 304, SS 316L, Monel, Titanium, Inconel 600, Hystalloy conform with or exceed Requirements of AISI, ASTM and API-ASME for recommended pressures. **Covers:** Encloses glass to reduce stress and resist glass breakage.

Bolts and Nuts: Alloy steel standard B7 & 2H, B8 & 8M. **Glasses:** Toughened Borosilicate Size 115, 140,165,190,220,250,280,320,340 for high strength and resistance to thermal shock.

Gaskets and cushions: IFG 5500, CAF, PTFE, Graphoil SS316 reinforced, Graphoil SS304 reinforced type die cut from quality material providing a long life.

CONNECTION TO GAUGE COCKS TYPE AND SIZE

Con. Top and Bottom		S	O
Threaded	1/2" NPT	x	
	3/4" NPT		x
Con. Side/back			
Threaded	1/2" NPT	x	
	3/4" NPT		x

S: Standard, O: Optional

GAUGE MODEL	COCK MODEL
PETL-30	PES-SP
PETL-30	PES-OP
PETL-30	PEB-SP

STANDARD DIMENSIONS

SECTIONS	MODEL	GLASS SIZE	VISIBLE LENGTH (MM)	OVERALL LENGTH(MM)
1	11-PETL-30	1	93	133
1	12-PETL-30	2	118	159
1	13-PETL-30	3	143	184
1	14-PETL-30	4	168	210
1	15-PETL-30	5	198	238
1	16-PETL-30	6	228	270
1	17-PETL-30	7	258	298
1	18-PETL-30	8	298	340
1	19-PETL-30	9	318	359
2	24-PETL-30	4	375	419
2	25-PETL-30	5	435	476
2	26-PETL-30	6	495	540
2	27-PETL-30	7	555	597
2	28-PETL-30	8	635	697
2	29-PETL-30	9	675	718
3	36-PETL-30	6	762	810
3	37-PETL-30	7	852	895
3	38-PETL-30	8	972	1019
3	39-PETL-30	9	1032	1076
4	47-PETL-30	7	1149	1194
4	48-PETL-30	8	1309	1359
4	49-PETL-30	9	1389	1435
5	57-PETL-30	7	1454	1492
5	58-PETL-30	8	1646	1699
5	59-PETL-30	9	1746	1794

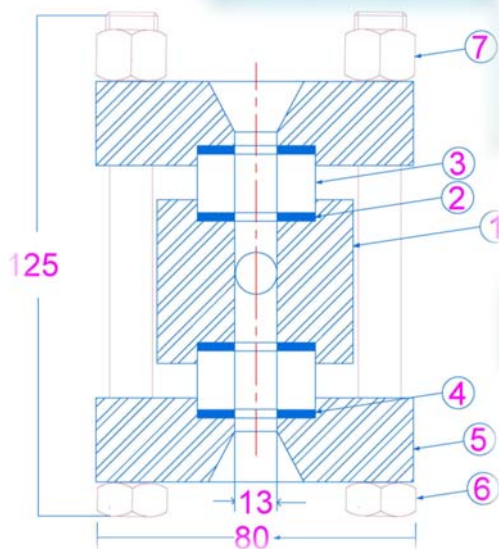
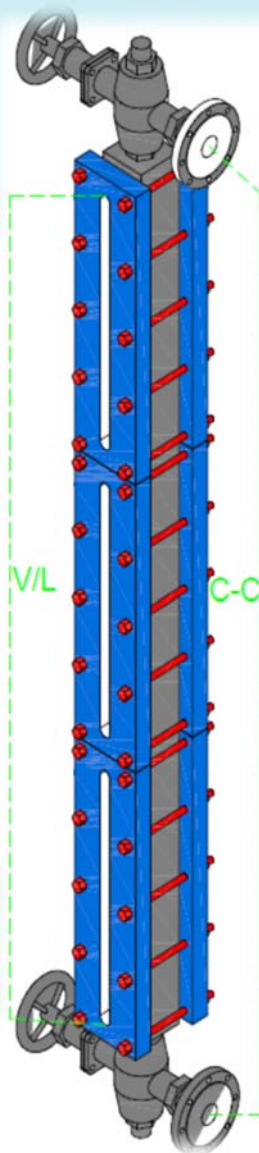

Temp (°F)	Maximum Pressure (psi)								
	PETL-30 Transparent Gauge								
	Glass Size								
	1	2	3	4	5	6	7	8	9
100	2000	1815	1630	1440	1250	1065	875	690	500
200	1930	1715	1580	1390	1210	1030	845	665	480
300	1870	1690	1520	1340	1170	995	815	645	465
400	1790	1620	1460	1290	1120	950	785	620	445
500	1660	1510	1360	1200	1040	890	730	575	415
600	1480	1340	1210	1060	920	790	645	510	370
750	1350	1230	1170	930	840	630	565	410	260

SR.NO	DESCRIPTION	MATERIAL
1	LIQUID CHAMBER	CS, ASTM A 105, SS 304, SS 316L, Monel, Titanium, Inconel 600, Hystalloy
2	GASKET	IFG 5500, CAF, PTFE, Graphoil SS316 reinforced, Graphoil SS304
3	GLASS	Toughened Borosilicate Size 115, 140,165,190,220,250,280,320,340
4	CUSHION	IFG 5500, CAF, PTFE, Graphoil SS316 reinforced, Graphoil SS304
5	COVER	CS, ASTM A 105, SS 304, SS 316L
6	BOLT	CS or SS304 or A 193 Gr. B7, CS or SS304 or A
7	NUT	193 Gr. 2H

TRANSPARENT LIQUID LEVEL GAUGE

TECHNICAL SPECIFICATION MODEL PETM-85

85 KG/CM² @ 121 °C/1200 PSI @ 250 °F

DESCRIPTION:

Series **PETM-85** is designed in both single and multiple sections. They are Standard Construction includes a solid one- piece chamber machined from carbon steel with covers, toughened glass and Chrome molybdenum bolts and nuts. All metal parts are rustproofed. Recessed gasket seat prevent movement and insure leak-free service. PETM-85 gauges are also available in a wide variety of materials to meet specific corrosive or extreme temperature

FEATURES:

Liquid Chamber: One piece Carbon steel or stainless steel, Regardless of number of gauges Sections. Standard and optional Materials CS, ASTM A 105, SS 304, SS 316L, Monel, Titanium, Inconel 600, Hystalloy conform with or exceed Requirements of AISI, ASTM and API-ASME for recommended pressures. **Covers:** Encloses glass to reduce stress and resist glass breakage. **Bolts and Nuts:** Alloy steel standard B7 & 2H, B8 & 8M. **Glasses:** Toughened Borosilicate Size 115, 140,165,190,220,250,280,320,340 for high strength and resistance to thermal shock. **Gaskets and cushions:** IFG 5500, CAF, PTFE, Graphoil SS316 reinforced, Graphoil SS304 reinforced type die cut from quality material

CONNECTION TO GAUGE COCKS TYPE AND SIZE

Con. Top and Bottom		S	O
Threaded	1/2" NPT	x	
	3/4" NPT		x
Con. Side/back			
Threaded	1/2" NPT	x	
	3/4" NPT		x

S: Standard, O: Optional

GAUGE MODEL	COCK MODEL
PETM-85	PES-SP
PETM-85	PES-OP
PETM-85	PEB-SP

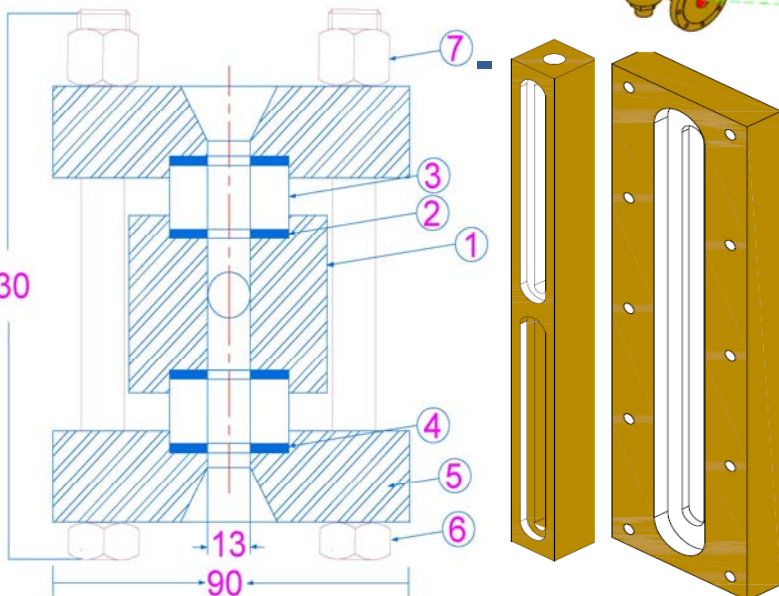
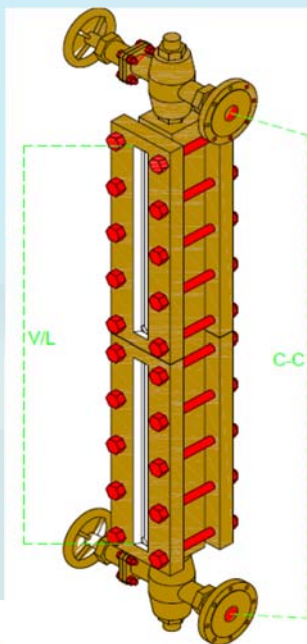

STANDARD DIMENSIONS

SECTIONS	MODEL	GLASS SIZE	VISIBLE LENGTH (MM)	OVERALL LENGTH(MM)
1	11-PETM-85	1	93	133
1	12-PETM-85	2	118	159
1	13-PETM-85	3	143	184
1	14-PETM-85	4	168	210
1	15-PETM-85	5	198	238
1	16-PETM-85	6	228	270
1	17-PETM-85	7	258	298
1	18-PETM-85	8	298	340
1	19-PETM-85	9	318	359
2	24-PETM-85	4	375	419
2	25-PETM-85	5	435	476
2	26-PETM-85	6	495	540
2	27-PETM-85	7	555	597
2	28-PETM-85	8	635	697
2	29-PETM-85	9	675	718
3	36-PETM-85	6	762	810
3	37-PETM-85	7	852	895
3	38-PETM-85	8	972	1019
3	39-PETM-85	9	1032	1076
4	47-PETM-85	7	1149	1194
4	48-PETM-85	8	1309	1359
4	49-PETM-85	9	1389	1435
5	57-PETM-85	7	1454	1492
5	58-PETM-85	8	1646	1699
5	59-PETM-85	9	1746	1794

Temp (°F)	Maximum Pressure (psi)								
	PETM-85 Transparent Gauge								
	Glass Size								
	1	2	3	4	5	6	7	8	9
100	2625	2500	2400	2350	2200	2100	1975	1850	1775
200	2475	2360	2200	2150	2000	1900	1825	1700	1625
300	2550	2150	2000	1900	1850	1700	1620	1550	1470
400	2000	1900	1800	1750	1600	1500	1450	1350	1300
500	1940	1850	1730	1620	1510	1465	1325	1235	1210
600	1000	970	940	900	870	830	800	850	650
750	850	830	800	770	750	720	700	750	550

SR.NO	DESCRIPTION	MATERIAL
1	LIQUID CHAMBER	CS, ASTM A 105, SS 304, SS 316L, Monel, Titanium, Inconel 600, Hystalloy
2	GASKET	IFG 5500, CAF, PTFE, Graphoil SS316 reinforced, Graphoil SS304
3	GLASS	Toughened Borosilicate Size 115, 140,165,190,220,250,280,320,340
4	CUSHION	IFG 5500, CAF, PTFE, Graphoil SS316 reinforced, Graphoil SS304
5	COVER	CS, ASTM A 105, SS 304, SS 316L
6	BOLT	CS or SS304 or A 193 Gr. B7, CS or SS304 or A 193 Gr. 2H
7	NUT	

TRANSPARENT LIQUID LEVEL GAUGE

TECHNICAL SPECIFICATION MODEL PETH-170

170 KG/CM² @ 100 °C/2400 PSI @ 212 °F

DESCRIPTION:

Series **PETH-170** is designed in both single and multiple sections. They are machined from solid bar stock of cold rolled carbon steel, stress relieved and assembled complete with drop forged steel covers, toughened Borosilicate glass, gasket, bolts and nuts making the gauges resistant to thermal shock, heat, corrosion and abrasion.

FEATURES:

Liquid Chamber: One piece Carbon steel or stainless steel, Regardless of number of gauges Sections. Standard and optional Materials CS, ASTM A 105, SS 304, SS 316L, Monel, Titanium, Inconel 600, Hystalloy conform with or exceed Requirements of AISI, ASTM and API-ASME for recommended pressures. **Covers:** Encloses glass to reduce stress and resist glass breakage. **Bolts and Nuts:** Alloy steel standard B7 & 2H, B8 & 8M. **Glasses:** Toughened Borosilicate Size 115, 140, 165, 190, 220, 250, 280, 320, 340 for high strength and resistance to thermal shock.

Gaskets and cushions: IFG 5500, CAF, PTFE, Graphoil SS316 reinforced, Graphoil SS304 reinforced type die cut from quality material providing a long life.

Shields- Glass Shields for excellent protection in corrosive environments and Mica Glass Shields for transparent gauges excellent protection in steam service

CONNECTION TO GAUGE COCKS TYPE AND SIZE

Con. Top and Bottom		S	O
Threaded	1/2" NPT	x	
	3/4" NPT		x
Con. Side/back			
Threaded	1/2" NPT	x	
	3/4" NPT		x

S: Standard, O: Optional

GAUGE MODEL	COCK MODEL
PETH-170	PES-SP
PETH-170	PEB -OP
PETH-170	PEB-SP

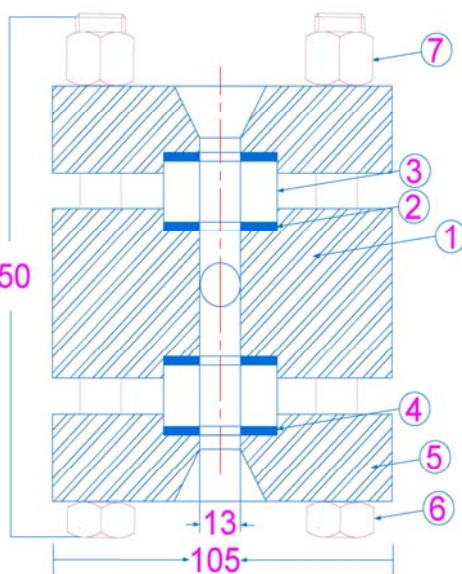
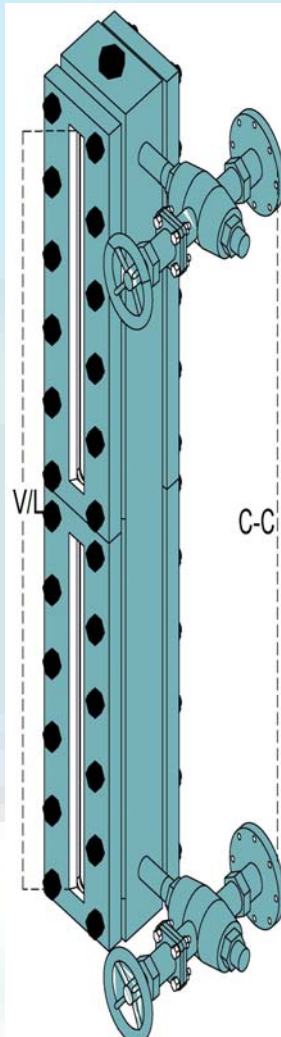

STANDARD DIMENSIONS

SECTIONS	MODEL	GLASS SIZE	VISIBLE LENGTH (MM)	OVERALL LENGTH(MM)
1	11-PETH-170	1	93	133
1	12-PETH-170	2	118	159
1	13-PETH-170	3	143	184
1	14-PETH-170	4	168	210
1	15-PETH-170	5	198	238
1	16-PETH-170	6	228	270
1	17-PETH-170	7	258	298
1	18-PETH-170	8	298	340
1	19-PETH-170	9	318	359
2	24-PETH-170	4	375	419
2	25-PETH-170	5	435	476
2	26-PETH-170	6	495	540
2	27-PETH-170	7	555	597
2	28-PETH-170	8	635	697
2	29-PETH-170	9	675	718
3	36-PETH-170	6	762	810
3	37-PETH-170	7	852	895
3	38-PETH-170	8	972	1019
3	39-PETH-170	9	1032	1076
4	47-PETH-170	7	1149	1194
4	48-PETH-170	8	1309	1359
4	49-PETH-170	9	1389	1435
5	57-PETH-170	7	1454	1492
5	58-PETH-170	8	1646	1699
5	59-PETH-170	9	1746	1794

Maximum Pressure (psi)

Temp (°F)	PETH-170 Transparent Gauge								
	Glass Size								
	1	2	3	4	5	6	7	8	9
100	3000	2850	2700	2600	2550	2400	2250	2100	2000
200	2800	2700	2600	2450	2400	2250	2100	2000	1900
300	2625	2500	2400	2350	2200	2100	1975	1850	1775
400	2475	2360	2200	2150	2000	1900	1825	1700	1625
500	2550	2150	2000	1900	1850	1700	1620	1550	1470
600	2000	1900	1800	1750	1600	1500	1450	1350	1300
750	1940	1850	1730	1620	1510	1465	1325	1235	1210

SR.NO	DESCRIPTION	MATERIAL
1	LIQUID CHAMBER	CS, ASTM A 105, SS 304, SS 316L, Monel, Titanium, Inconel 600, Hystalloy
2	GASKET	IFG 5500, CAF, PTFE, Graphoil SS316 reinforced, Graphoil SS304
3	GLASS	Toughened Borosilicate Size 115, 140, 165, 190, 220, 250, 280, 320, 340
4	CUSHION	IFG 5500, CAF, PTFE, Graphoil SS316 reinforced, Graphoil SS304
5	COVER	CS, ASTM A 105, SS 304, SS 316L
6	BOLT	CS or SS304 or A 193 Gr. B7, CS or SS304 or A
7	NUT	193 Gr. 2H

TRANSPARENT LIQUID LEVEL GAUGE

TECHNICAL SPECIFICATION MODEL PETHH-220

220 KG/CM² @ 100 °C/3130 PSI @ 212

DESCRIPTION:

Series **PETHH-220** is designed in both single and multiple sections. They are machined from solid bar stock of cold rolled carbon steel, stress relieved and assembled complete with drop forged steel covers, toughened Borosilicate glasses, gasket, bolts and nuts making the gauges resistant to thermal shock, heat, corrosion and abrasion.

FEATURES:

Liquid Chamber: One piece Carbon steel or stainless steel, Regardless of number of gauges Sections. Standard and optional Materials CS, ASTM A 105, SS 304, SS 316L, Monel, Titanium, Inconel 600, Hastalloy conform with or exceed Requirements of AISI, ASTM and API-ASME for recommended pressures. **Covers:** Encloses glass to reduce stress and resist glass breakage. **Bolts and Nuts:** Alloy steel standard B7 & 2H, B8 & 8M. **Glasses:** Toughened Borosilicate Size 115, 140, 165, 190, 220, 250, 280, 320, 340 for high strength and resistance to thermal shock.

Gaskets and cushions: IFG 5500, CAF, PTFE, Graphoil SS316 reinforced, Graphoil SS304 reinforced type die cut from quality material providing a long life.

Shields- Glass Shields for excellent protection in corrosive environments and Mica Glass Shields for transparent gauges excellent protection in steam service

CONNECTION TO GAUGE COCKS TYPE AND SIZE

Con. Top and Bottom		S	O
Threaded	1/2" NPT	x	
	3/4" NPT		x
Con. Side/back			
Threaded	1/2" NPT	x	
	3/4" NPT		x

S: Standard, O: Optional

GAUGE MODEL	COCK MODEL
PETHH-220	PES-SP
PETHH-220	PEB-OP
PETHH-220	PEB-SP

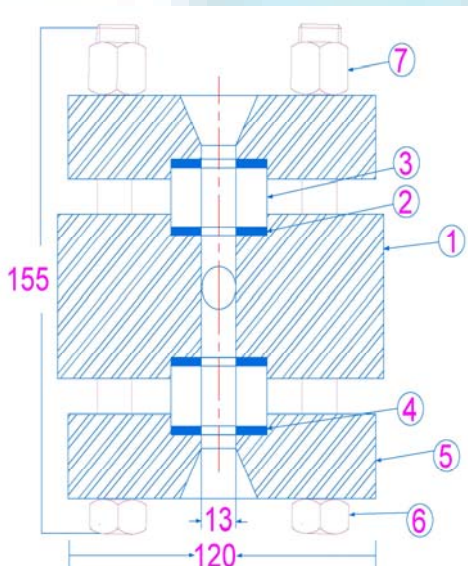
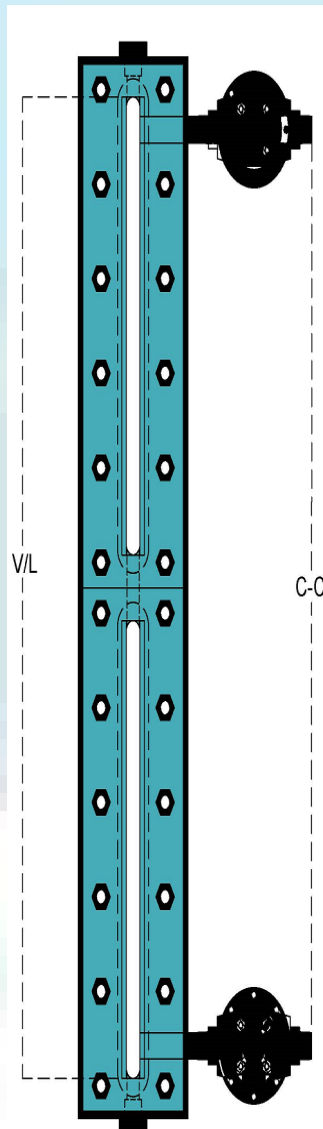

STANDARD DIMENSIONS

SECTIONS	MODEL	GLASS SIZE	VISIBLE LENGTH (MM)	OVERALL LENGTH(MM)
1	11-PETHH-220	1	93	133
1	12-PETHH-220	2	118	159
1	13-PETHH-220	3	143	184
1	14-PETHH-220	4	168	210
1	15-PETHH-220	5	198	238
1	16-PETHH-220	6	228	270
1	17-PETHH-220	7	258	298
1	18-PETHH-220	8	298	340
1	19-PETHH-220	9	318	359
2	24-PETHH-220	4	375	419
2	25-PETHH-220	5	435	476
2	26-PETHH-220	6	495	540
2	27-PETHH-220	7	555	597
2	28-PETHH-220	8	635	697
2	29-PETHH-220	9	675	718
3	36-PETHH-220	6	762	810
3	37-PETHH-220	7	852	895
3	38-PETHH-220	8	972	1019
3	39-PETHH-220	9	1032	1076
4	47-PETHH-220	7	1149	1194
4	48-PETHH-220	8	1309	1359
4	49-PETHH-220	9	1389	1435
5	57-PETHH-220	7	1454	1492
5	58-PETHH-220	8	1646	1699
5	59-PETHH-220	9	1746	1794

Temp (°F)	Maximum Pressure (psi)								
	PETHH-220 Transparent Gauge								
	Glass Size								
	1	2	3	4	5	6	7	8	9
100	5000	4885	4770	4450	4350	4225	4150	3925	3800
200	4685	4572	4400	4350	4190	3930	3850	3550	3400
300	4370	4230	4110	3960	3820	3740	3680	3380	3290
400	4000	3850	3700	3600	3450	3300	3200	3100	3000
500	3800	3700	3500	3400	3300	3150	3050	2950	2800
600	3600	3500	3300	3250	3100	3000	2900	2800	2650
750	3350	3200	3100	3000	2900	2800	2700	2550	2450

SR.NO	DESCRIPTION	MATERIAL
1	LIQUID CHAMBER	CS, ASTM A 105, SS 304, SS 316L, Monel, Titanium, Inconel 600, Hastalloy
2	GASKET	IFG 5500, CAF, PTFE, Graphoil SS316 reinforced, Graphoil SS304
3	GLASS	Toughened Borosilicate Size 115, 140, 165, 190, 220, 250, 280, 320, 340
4	CUSHION	IFG 5500, CAF, PTFE, Graphoil SS316 reinforced, Graphoil SS304
5	COVER	CS, ASTM A 105, SS 304, SS 316L
6	BOLT	CS or SS304 or A 193 Gr. B7, CS or SS304 or A 193 Gr. 2H
7	NUT	

TRANSPARENT LIQUID LEVEL GAUGE

TECHNICAL SPECIFICATION MODEL PETLC-28

28 KG/CM² @ 150 °C/400 PSI @ 302 °F

DESCRIPTION:

Series **PETLC-28** is designed to give a more accurate reading for liquids that have a tendency to surge or boil, then could be achieved with the standard gauges. The covers are drop forged, machined to fit the contour of the glass and provide full support for the front cushion gaskets in between.

FEATURES:

Liquid Chamber: One piece Carbon steel or stainless steel, Regardless of number of gauges Sections. Standard and optional Materials CS, ASTM A 105, SS 304, SS 316L, Monel, Titanium, Inconel 600, Hystalloy conform with or exceed Requirements of AISI, ASTM and API-ASME for recommended pressures. **Covers:** Encloses glass to reduce stress and resist glass breakage.

Bolts and Nuts: Alloy steel standard B7 & 2H, B8 & 8M. **Glasses:** Toughened Borosilicate Size 115, 140,165,190,220,250,280,320,340 for high strength and resistance to thermal shock.

Gaskets and cushions: IFG 5500, CAF, PTFE, Graphoil SS316 reinforced, Graphoil SS304 reinforced type die cut from quality material providing a long life.

CONNECTION TO GAUGE COCKS TYPE AND SIZE

Con. Top and Bottom		S	O
Threaded	1/2" NPT	x	
	3/4" NPT		x
Con. Side/back			
Threaded	1/2" NPT	x	
	3/4" NPT		x

S: Standard, O: Optional

GAUGE MODEL	COCK MODEL
PETLC-28	PES-SP
PETLC-28	PES-OP
PETLC-28	PEB-SP

STANDARD DIMENSIONS

SECTIONS	MODEL	GLASS SIZE	VISIBLE LENGTH (MM)	OVERALL LENGTH(MM)
1	11-PETLC-28	1	93	133
1	12-PETLC-28	2	118	159
1	13-PETLC-28	3	143	184
1	14-PETLC-28	4	168	210
1	15-PETLC-28	5	198	238
1	16-PETLC-28	6	228	270
1	17-PETLC-28	7	258	298
1	18-PETLC-28	8	298	340
1	19-PETLC-28	9	318	359
2	24-PETLC-28	4	375	419
2	25-PETLC-28	5	435	476
2	26-PETLC-28	6	495	540
2	27-PETLC-28	7	555	597
2	28-PETLC-28	8	635	697
2	29-PETLC-28	9	675	718
3	36-PETLC-28	6	762	810
3	37-PETLC-28	7	852	895
3	38-PETLC-28	8	972	1019
3	39-PETLC-28	9	1032	1076
4	47-PETLC-28	7	1149	1194
4	48-PETLC-28	8	1309	1359
4	49-PETLC-28	9	1389	1435
5	57-PETLC-28	7	1454	1492
5	58-PETLC-28	8	1646	1699
5	59-PETLC-28	9	1746	1794

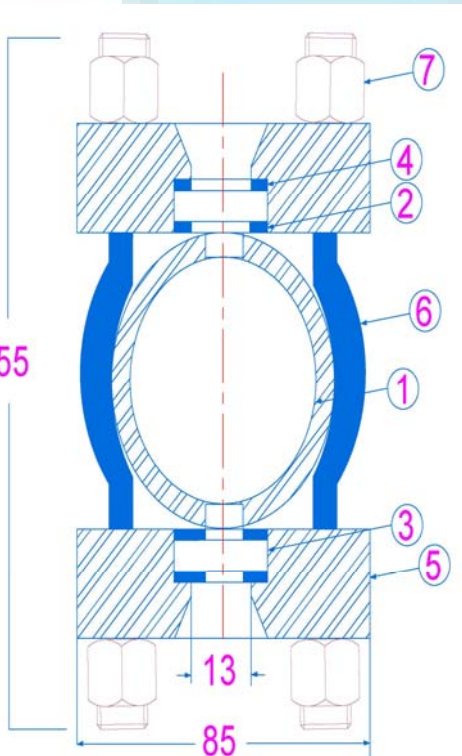
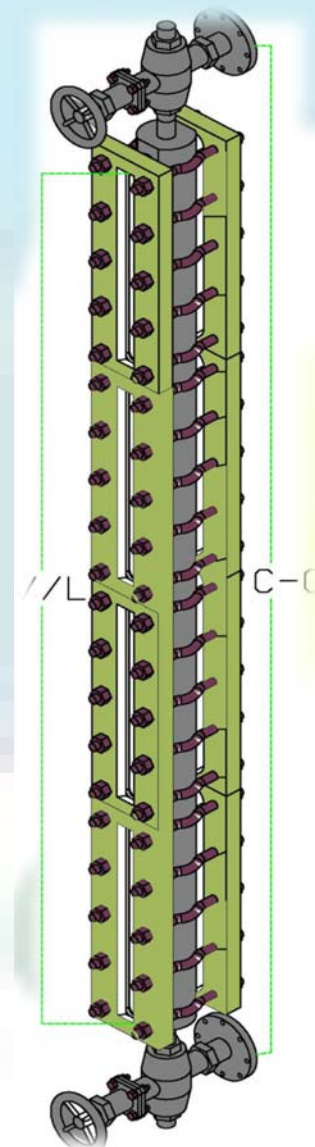

Temp (°F)	Maximum Pressure (psi)								
	PETLC-28 Transparent Gauge								
	Glass Size								
	1	2	3	4	5	6	7	8	9
100	1500	1450	1400	1350	1300	1250	1200	1100	1000
200	1400	1350	1300	1250	1200	1150	1100	1050	950
300	1300	1250	1200	1150	1100	1050	1000	950	850
400	1150	1100	1070	1040	1000	950	900	900	750
500	1000	970	940	900	870	830	800	850	650

SR.NO	DESCRIPTION	MATERIAL
1	LIQUID CHAMBER	CS, ASTM A 105, SS 304, SS 316L
2	GASKET	IFG 5500, CAF, PTFE, Graphoil SS316 reinforced, Graphoil SS304
3	GLASS	Toughened Borosilicate Size 115, 140,165,190,220,250,280,320,340
4	CUSHION	IFG 5500, CAF, PTFE, Graphoil SS316 reinforced, Graphoil SS304
5	COVER	CS, ASTM A 105, SS 304, SS 316L
6	BOLT	CS or SS304 or A 193 Gr. B7, CS or SS304 or A 193 Gr. 2H
7	NUT	

TRANSPARENT LIQUID LEVEL GAUGE

TECHNICAL SPECIFICATION

MODEL PETW-120

120 KG/CM² @ 37 °C/1700 PSI @ 100 °F

DESCRIPTION:

Series **PETW-120** is designed to be welded directly to a vessel or other liquid containing vessels. The body lengths and visibility are the same as standard gauges in single or multiple types. These gauges consist of a pad which is machined from bar stock, standard forged covers, glass, gaskets and bolts.

FEATURES:

Liquid Chamber: One piece Carbon steel or stainless steel, Regardless of number of gauges Sections. Standard and optional Materials CS, ASTM A 105, SS 304, SS 316L, Monel, Titanium, Inconel 600, Hastalloy conform with or exceed Requirements of AISI, ASTM and API-ASME for recommended pressures. **Covers:** Encloses glass to reduce stress and resist glass breakage.

Bolts and Nuts: Alloy steel standard B7 & 2H, B8 & 8M. **Glasses:** Toughened Borosilicate Size 115, 140,165,190,220,250,280,320,340 for high strength and resistance to thermal shock.

Gaskets and cushions: IFG 5500, CAF, PTFE, Graphoil SS316 reinforced, Graphoil SS304 reinforced type die cut from quality material providing a long life.

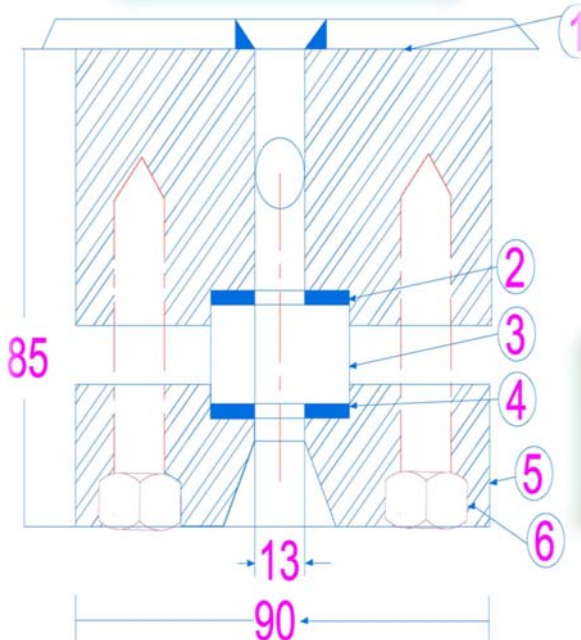
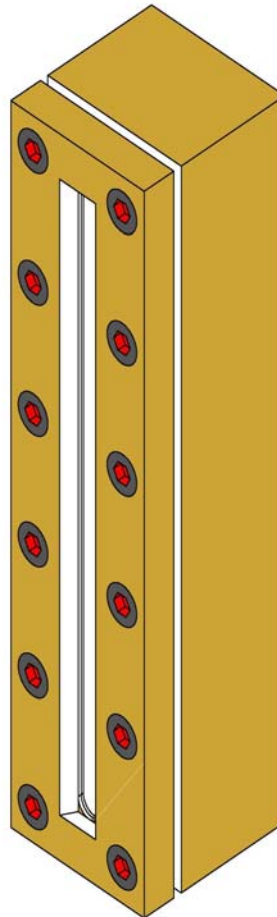

STANDARD DIMENSIONS

SECTIONS	MODEL	GLASS SIZE	VISIBLE LENGTH (MM)	OVERALL LENGTH(MM)
1	11-PETW-120	1	93	133
1	12-PETW-120	2	118	159
1	13-PETW-120	3	143	184
1	14-PETW-120	4	168	210
1	15-PETW-120	5	198	238
1	16-PETW-120	6	228	270
1	17-PETW-120	7	258	298
1	18-PETW-120	8	298	340
1	19-PETW-120	9	318	359
2	24-PETW-120	4	375	419
2	25-PETW-120	5	435	476
2	26-PETW-120	6	495	540
2	27-PETW-120	7	555	597
2	28-PETW-120	8	635	697
2	29-PETW-120	9	675	718
3	36-PETW-120	6	762	810
3	37-PETW-120	7	852	895
3	38-PETW-120	8	972	1019
3	39-PETW-120	9	1032	1076
4	47-PETW-120	7	1149	1194
4	48-PETW-120	8	1309	1359
4	49-PETW-120	9	1389	1435
5	57-PETW-120	7	1454	1492
5	58-PETW-120	8	1646	1699
5	59-PETW-120	9	1746	1794

Temp (°F)	Maximum Pressure (psi)								
	PETW-120 Transparent Gauge								
	Glass Size								
	1	2	3	4	5	6	7	8	9
100	1990	1785	1645	1539	1395	1254	1160	856	800
200	1870	1695	1573	1400	1300	1187	1000	835	760
300	1600	1430	1376	1200	1110	1000	840	790	600

SR.NO	DESCRIPTION	MATERIAL
1	CHAMBER	CS, ASTM A 105, SS 304, SS 316L
2	GASKET	IFG 5500, CAF, PTFE, Graphoil SS316 reinforced, Graphoil SS304
3	GLASS	Toughened Borosilicate Size 115, 140,165,190,220,250,280,320,340
4	CUSHION	IFG 5500, CAF, PTFE, Graphoil SS316 reinforced, Graphoil SS304
5	COVER	CS, ASTM A 105, SS 304, SS 316L
6	BOLT	CS or SS304 or A 193 Gr. B7, CS or SS304 or A 193 Gr. 2H

TRANSPARENT AND REFLEX LIQUID LEVEL GAUGE ACCESSORIES ISOLATION VALVE (GAUGE COCK)

Petrotech Isolation valves have been specifically designed for use with liquid level gauges and are available in a variety of materials suitable for temperature and pressure ranges to meet most specifications. Valves are available in both straight and offset pattern designs with outside screw and yolk (OS&Y) or inside screw configurations and have a selection of vessel and gauge connections to fit a variety of mounting requirements.

A standard feature with Petrotech Valves is the automatic safety ball checks. In the event of the glass breaking the ball check seats to prevent the loss of vessel contents. All valves may be repacked under pressure with the back seating arrangement ensuring complete shut off.

1) straight pattern screw type isolation valve (MODEL-PES-SP)

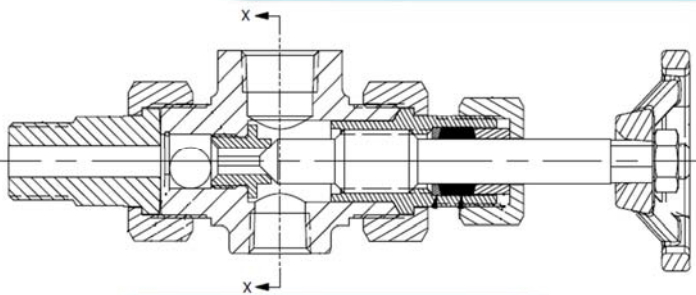

2) Offset pattern screw type isolation valve (MODEL-PES-OP)

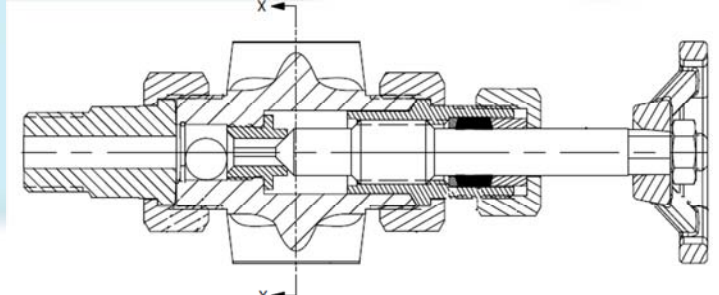

3) Straight Pattern Bolted Bonnet Type Isolation Valve (MODEL-PEB-SP)

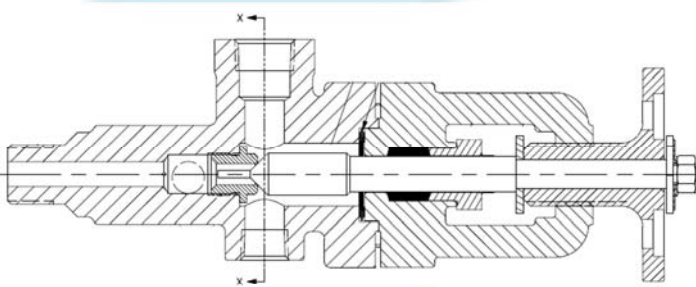

4) Offset Pattern Bolted Bonnet Type Isolation Valve (MODEL-PEB-OP)

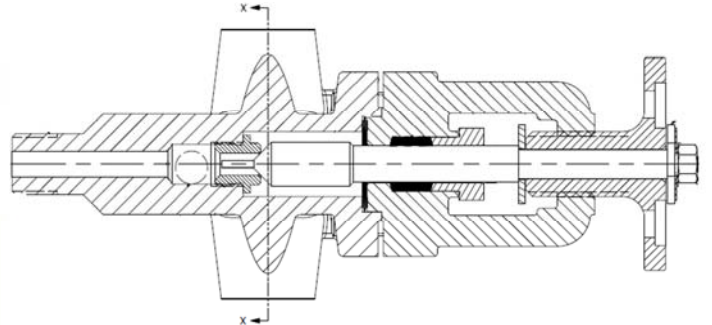

PROCESS CONNECTION

1) FLANGE

2) SCREW

4) SOCKET WELD

3) SPHERICAL UNION

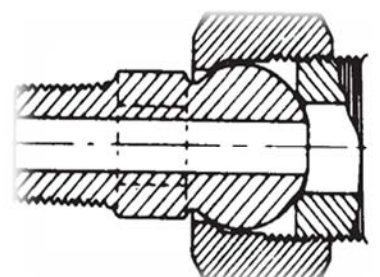
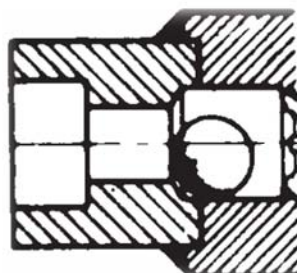
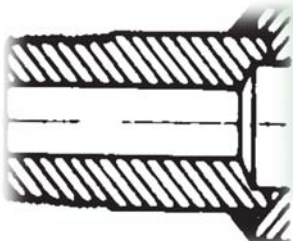
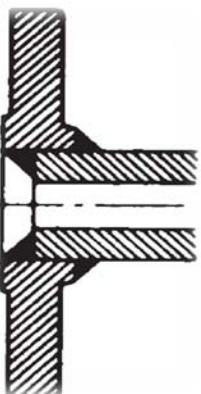

GAUGE CONNECTION AND ISOLATION VALVE

4) Top/Bottom straight pattern valve Connection

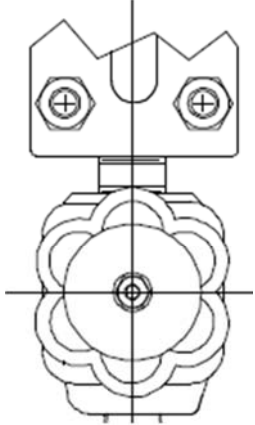

3) Side / Side straight pattern valve Connection

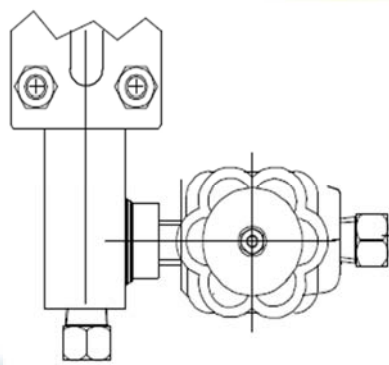

2) Top/Bottom offset pattern valve Connection

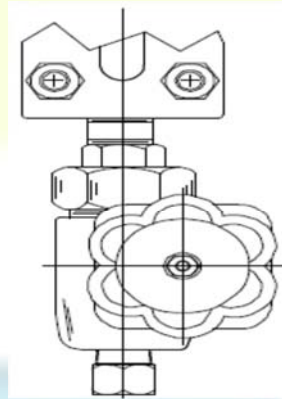

1) Side / Side offset pattern valve Connection

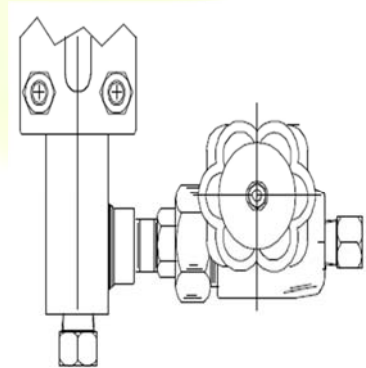

HEATING AND COOLING JACKETING

Heating and cooling jacketing is designed for use with liquid of poor fluidity and therefore difficult to measure. A jacket is fitted up the level gauge and gauge valve and steam or heated water is passed through this jacket to improve the fluidity of the liquid and this makes measuring easy. The same gauge can be used as a cooling type gauge.

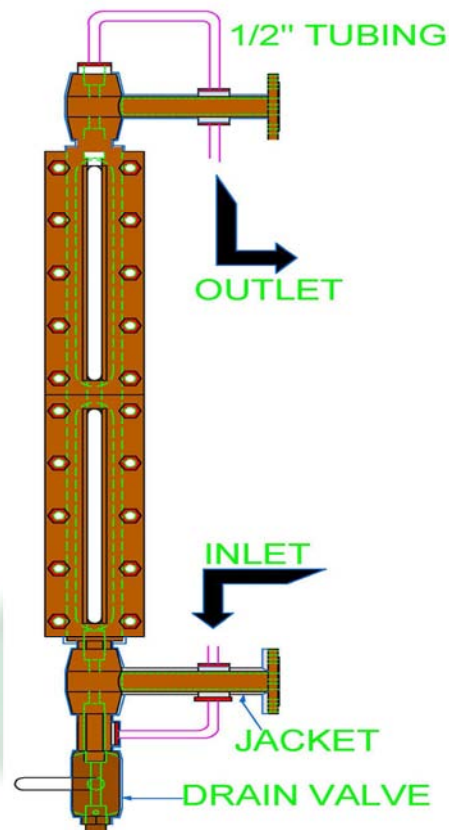

ILLUMINATOR

Illuminators are designed for liquid observation on transparent gauges when ambient light is insufficient. The diffusion of light is over the entire length of the gauge glass, with no glare spots or blinding areas. Available for Transparent Liquid Level Gauges and All units are dust-tight and explosion-proof approved Class 1, Division II, Groups B, C and D service.

ILLUMINATOR

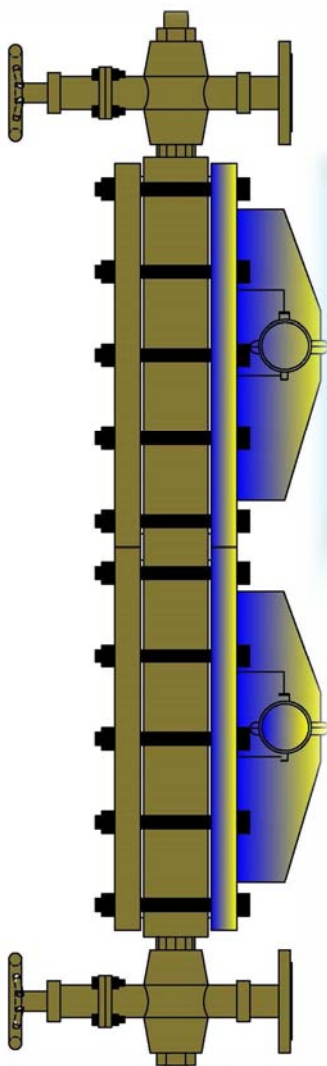

NON- FROSTING

TRANSPARENT

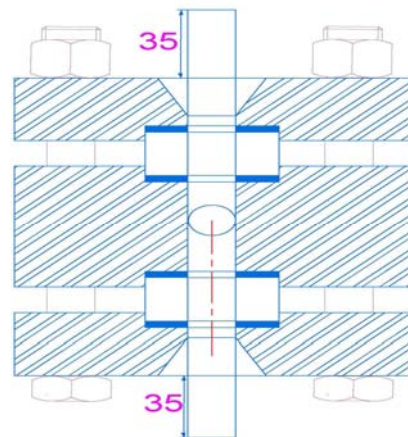

REFLEX

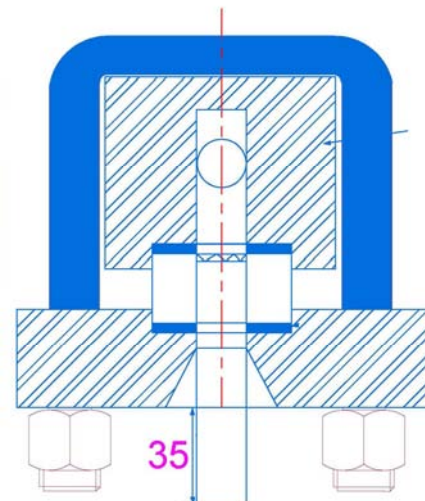

NON FROSTING

Non-Frosting consists in transparent piece in direct contact with the gauge glass. It extends the vision so frost cannot build up across the vision slot.

ORIENTATION OF PROCESS CONNECTION

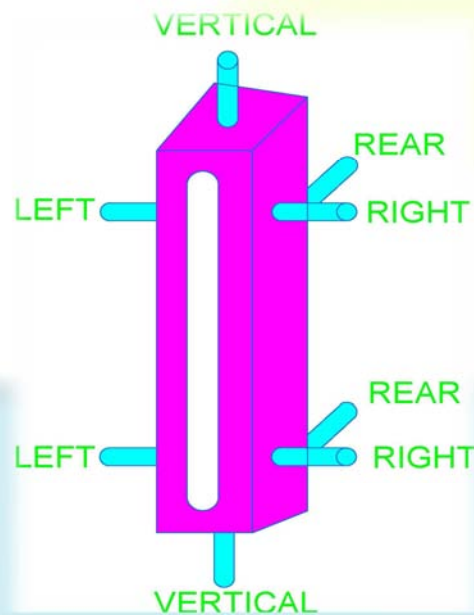

MICA SHIELDS

For Reflex and Transparent Level Gauges are made of the highest quality ruby mica, cut and punched to accurate specified dimensions and thickness, having very high degree of thru vision transparency – rigidly tested and inspected to eliminate imperfections. On steam water services in excess of 35 bar use transparent gauges mica protection.

SCALES

Scale is constructed of corrosion resistant materials like SS, aluminum with cladding. They are available in mm, cm, inches, etc.



Petrotech Engineers

Office: 485-486 /A-3

Makarpura GIDC

Vadodara – 390010.Gujarat. India

Website: www.petrotechengineers.com

Email : info@petrotechengineers.com